



NORO

MAGAZINE

Unwind Top



11 Unwind Top

●●○○ EASY



Sizes

Sized for Small (Medium, Large, X-Large, 2X-Large, 3X-Large) and shown in size Small.

Finished Measurements

- Bust 43 (45, 47, 49, 51, 54)in/109 (114, 119, 124, 130, 137)cm.
- Length 22 (22½, 23, 23½, 24)in/56 (57, 58.5, 58.5, 60, 61)cm.

Materials

- 2 x 200g ball of Noro *Kakigori* in #13.
- One pair size US 6/4mm needles.
- One pair size US 8/5mm needles or size to obtain gauge.
- Clip-on stitch markers.

Gauge

18 sts and 26 rows to 4in/10cm over Stockinette st using larger needles.

TAKE TIME TO CHECK GAUGE.

General and Knitting Abbreviations

approx approximately; **beg** begin(ning); **CC** contrasting color; **cm** centimeter(s); **cn** cable needle; **cont** continue(ing); **dec** decrease(ing); **dpn** double-pointed needle(s); **est** established; **fol** follow(s) (ing); **g** gram(s); **in** inch(es); **inc** increase(ing); **k** knit; **kfb** knit into front and back of stitch; **LH** left-hand; **mm** millimeter(s); **MC** main color; **MI** make one (see glossary); **p** purl; **patt(s)** pattern(s); **pm** place marker; **psso** pass slip stitch(es) over; **rem** remain(s) (ing); **rep** repeat; **rev** reverse(ing) (ed); **RH** right-hand; **rnd(s)** round(s); **RS** right side; **SKP** slip 1, knit 1, pass slip stitch over; **SK2P** slip 1, knit 2 stitches together, pass slip stitch over k2tog; **S2KP** slip 2 stitches together knitwise, knit 1, pass slip stitches over knit 1; **sl** slip; **sm** slip marker; **ssk/ssp** slip, slip, knit/purl (see glossary); **st(s)** stitch(es); **St st** Stockinette stitch; **tbl** through back loop; **tog** together; **WS** wrong side(s); **wyib** with yarn in back; **wyif** with yarn in front; **yo** yarn over (hook or needle); * repeat directions following * as many times as indicated; [] repeat directions inside brackets as many times as indicated.

Glossary

bind off To finish off an edge and keep stitches from unraveling by lifting the first stitch over the second, the second over the third, etc. (UK: cast off).

bind off in ribbing Maintain the rib pattern as you bind off (knit the knit stitches; purl the purl stitches) (UK: cast off in ribbing)

cast on Form a foundation row by making specified number of loops on the knitting needle.

decrease Reduce the number of stitches in a row (i.e., knit 2 together; purl 2 together).

increase Add to the number of stitches in a row (i.e., knit in front and back of stitch).

knitwise Insert the needle into the stitch as if you were going to knit it.

make one Insert tip of LH needle from front to back under the strand between the last stitch worked and the next stitch on the needle. Knit into the back loop to increase one stitch.

make one purl stitch With the needle tip, lift the strand between the last stitch worked and the next stitch on left-hand needle and purl it. One purl stitch has been added.

no stitch On some charts, “no stitch” is indicated with shaded spaces where stitches have been decreased or not yet made. In such cases, work the stitches of the chart, skipping over the “no stitch” spaces.

place markers Loop a piece of contrasting yarn or a purchased stitch marker onto the needle.

pick up and knit/purl Knit (or purl) into the loops along an edge.

purlwise Insert the needle into the stitch as if you were going to purl it.

selvage stitch Edge stitch that helps make seaming easier.

skip Skip specified number of stitches of the previous row and work into next stitch (UK: miss).

slip, slip, knit/purl Slip next two sts knitwise (purlwise), one at a time, to right-hand needle. Insert tip of left-hand needle into fronts of these sts from left to right and knit/purl them together to decrease one stitch.

slip stitch In knitting, pass a stitch from the left-hand to the right-hand needle as if to purl without working it. In crochet, insert hook through loop or edge, yarn over and pull through loop on hook (UK: ss or sc).

work even Continue in specified pattern without increasing or decreasing (UK: work straight).

yarn over In knitting, make a new stitch by placing the yarn over the right-hand needle (UK: yfwd, yon, yrn). In crochet, wind yarn around hook. (UK: yoh or yrh).

Back

With smaller needles, cast on 98 (101, 107, 110, 116, 122) sts. Knit 4 rows.

Change to larger needles.

Begin Pattern Stitch

** Row 1 (RS) Purl.

Row 2 P1, p each st wrapping yarn twice around needle, end p1.

Row 3 K1, *sl next 3 sts to RH needle dropping extra loops, then sl these same 3 sts back to LH needle and k3tog (leaving sts on LH needle), yo, k3tog the same sts again; rep from * to last st, end k1.

Row 4 (WS) Knit**.

Row 5 Knit.

Row 6 Purl.

Row 7 Knit.

Row 8 Purl.

Rows 9–32 Rep rows 1–8 three times.

Rows 33–36 Rep rows 1–4 once.

Next row (RS) Knit.

Next row (WS) Purl.

Rep last 2 rows for St st until piece measures 21¼ (21¾, 22¼, 22¼, 22¾, 23¼)in/54 (55, 56.5, 56.5, 58, 59)cm from beg.

Change to smaller needles.

Rep between **'s (rows 1–4) once more.

Next row (RS) Purl.

Bind off.

Front

Work same as for back.

Pre-Finishing

Place marker at 22 (23, 26, 28, 31, 34) sts in from each shoulder edge neck opening. Sew shoulder seams up to markers for neck, leaving 12in/30.5cm between markers open for neck opening. Reinforce at neckline edges for durability.

Sleeve Trims

Place markers on front and back at 7 (7½, 7¾, 8, 8½, 9)in/18 (19, 19.5, 20.5, 21, 23)cm down from shoulders.

With smaller needles, pick up and k 65 (68, 71, 74, 77, 80) sts between markers along one seamed shoulder side.

11 Unwind Top



Next row (WS) Purl.
 Rows 1-8 Work as for back.
 Rows 9-12 Rep rows 1-4 once.
 Next row (RS) Purl.
 Next row (WS) Knit.
 Bind off. Rep for other sleeve trim.

Finishing

Sew side and underarm sleeve trims. ■

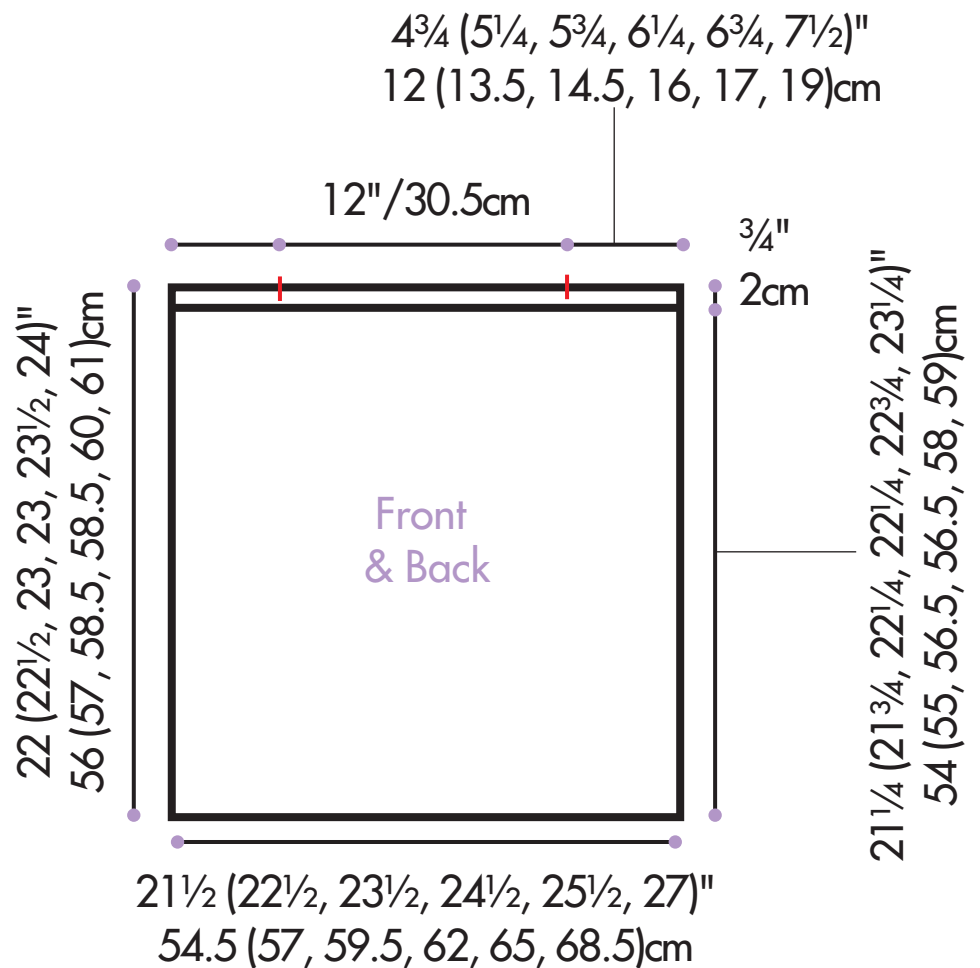

— = Place marker