



NORO

KNITTING MAGAZINE | **Boxy Pullover**



01 Boxy Pullover

●●●○ INTERMEDIATE



Sizes

Sized for Small (Medium, Large, X-Large) and shown in size Medium.

Finished Measurements

- Bust 39½ (42, 44, 46)in/100 (106.5, 111.5, 117)cm.
- Length 23½ (24¼, 25, 25¾)in/59.5 (61.5, 63.5, 65.5)cm.
- Upper arm 16½ (17¾, 19, 20½)in/42 (45, 48, 52)cm.

Materials

- 2 (2, 3, 3) x 100g balls of Noro *Silk Garden Sock Solo* in #31 (A).
- 2 (2, 3, 3) x 100g balls of Noro *Silk Garden Sock* in #S437 (B).
- One pair size US 4 (3.5mm) needles, OR SIZE TO OBTAIN GAUGE
- One pair size US 10 (6mm) needles, OR SIZE TO OBTAIN GAUGE.
- Stitch holders.
- Clip-on stitch markers.

Gauges

- 18 sts and 20 rows = 4in/10cm over Stockinette stitch using size US 10 (6mm) needles.
- 18 sts and 28 rows = 4in/10cm over Garter stitch using size US 10 (6mm) needles.

TAKE TIME TO CHECK GAUGES

Knitting Abbreviations

approx approximately; **beg** begin(ning); **CC** contrasting color; **cm** centimeter(s), **cn** cable needle; **cont** continue(ing); **dec** decrease(ing); **dpn** double-pointed needle(s); **est** established; **fall** follow(s)(ing); **g** gram(s); **inc** increase(ing); **k** knit; **kfb** knit into front and back of stitch; **LH** left-hand; **mm** millimeter(s); **MC** main color; **M1** make one (see glossary); **p** purl; **pat(t)s** pattern(s); **pm** place marker; **psso** pass slip stitch(es) over; **rem** remain(s)(ing); **rep** repeat; **rev** reverse(ing)(ed); **RH** right-hand; **rnd(s)** round(s); **RS** right side; **SKP** slip 1, knit 1, pass slip stitch over; **SK2P** slip 1, knit 2 stitches together, pass slip stitch over k2tog; **S2KP** slip 2 stitches together knitwise, knit 1, pass slip stitches over knit 1; **sl st** slip stitch; **ssk/ssp** slip, slip, knit/purl (see glossary); **st(s)** stitch(es); **St st** Stockinette stitch; **tbl** through back loop; **tog** together; **WS** wrong side(s); **wyib** with yarn in back; **wyif** with yarn in front; **yo** yarn over (hook or needle); * repeat directions following * as many times as indicated; [] repeat directions inside brackets as many times as indicated.

Crochet Abbreviations

BP back post; **BPdc** back post double crochet; **BPsc** back post single crochet; **BPtr** back post treble crochet; **ch** chain(s); **ch-** refers to chain or space previously made (i.e., ch-1 space); **ch-sp** chain space previously made; **dc** double crochet (UK: tr=treble); **dc2tog** double crochet 2 stitches together; **dtr** double treble (UK: trtr=triple treble); **FP** front post; **FPdc** front post double crochet; **FPsc** front post single crochet; **FPtr** front post treble crochet; **grp(s)** group(s); **hdc** half double crochet (UK: htr=half treble); **lp(s)** loop(s); **sc** single crochet (UK: dc=double crochet); **sc2tog** single crochet 2 stitches together; **sk** skip(ped); **sl st** slip stitch (UK: sc=single crochet); **sp(s)** space(s); **t-ch** turning chain; **tr** treble (UK: dtr=double treble); **trtr** triple treble (UK: qtr=quadruple treble).

Glossary

bind off To finish off an edge and keep stitches from unraveling by lifting the first stitch over the second, the second over the third, etc. (UK: cast off).

bind off in ribbing Maintain the rib pattern as you bind off (knit the knit stitches; purl the purl stitches) (UK: cast off in ribbing)

cast on Form a foundation row by making specified number of loops on the knitting needle.

decrease Reduce the number of stitches in a row (i.e., knit 2 together; purl 2 together).

increase Add to the number of stitches in a row (i.e., knit in front and back of stitch).

knitwise Insert the needle into the stitch as if you were going to knit it.

make one Insert tip of LH needle from front to back under the strand between the last stitch worked and the next stitch on the needle. Knit into the back loop to increase one stitch.

make one purl stitch With the needle tip, lift the strand between the last stitch worked and the next stitch on left-hand needle and purl it. One purl stitch has been added.

no stitch On some charts, "no stitch" is indicated with shaded spaces where stitches have been decreased or not yet made. In such cases, work the stitches of the chart, skipping over the "no stitch" spaces.

place markers Loop a piece of contrasting yarn or a purchased stitch marker onto the needle.

pick up and knit/purl Knit (or purl) into the loops along an edge.

purlwise Insert the needle into the stitch as if you were going to purl it.

selvage stitch Edge stitch that helps make seaming easier.

skip Skip specified number of stitches of the previous row and work into next stitch (UK: miss).

slip, slip, knit/purl Slip next two sts knitwise (purlwise), one at a time, to right-hand needle. Insert tip of left-hand needle into fronts of these sts from left to right and knit/purl them together to decrease one stitch.

slip stitch In knitting, pass a stitch from the left-hand to the right-hand needle as if to purl without working it. In crochet, insert hook through loop or edge, yarn over and pull through loop on hook (UK: ss or sc).

work even Continue in specified pattern without increasing or decreasing (UK: work straight).

yarn over In knitting, make a new stitch by placing the yarn over the right-hand needle (UK: yfwd, yon, yrn). In crochet, wind yarn around hook. (UK: yoh or yrh).

Notes

1. Make front first.
2. The overall loose gauge will make the fit more oversized than the measurements imply.

Front

With size US 4 (3.5mm) needles and A, cast on 71 (77, 83, 89) sts. [Knit 1 row, purl 1 row] twice.

Next row (RS) K1, *p1, k1; rep from * to end.

Next row (WS) P1, *k1, p1; rep from * to end.

Next row (RS) [K3, k2tog] 14 (15, 16, 17) times, k1 (2, 3, 4)—57 (62, 67, 72) sts.

**** Row 1 (WS)** P2, k1, p to last 3 sts, k1, p2.

Row 2 (RS) K2, p1, k to last 3 sts, p1, k2.

Rows 3–9 Rep these last 2 rows for 7 rows more.

This ends the side slit **.

Begin stripe pattern

Change to B and size US 10 (6mm) needles. The remainder of the piece is knit using this needle size and the 3–st trim each side of the slit will be discontinued.

01 Boxy Pullover



Section 1

Inc row (RS) With B, k1, kfb, k to last 3 sts, kfb, k2.

Rows 2–12 Knit.

Row 13 Rep inc row.

Rows 14–20 Knit.

Section 2

Rows 1 and 2 With A, knit 1 row, purl 1 row.

Row 3 Rep inc row.

Rows 4–10 With A, purl 1 row, [knit 1 row, purl 1 row] 3 times.

Row 11 Rep inc row.

Rows 12–18 Rep rows 4–10.

Row 19 Rep inc row.

Rows 20–26 Rep rows 4–10.

Row 27 Rep inc row.

Rows 28–30 Purl 1 row, knit 1 row, purl 1 row.

Section 3

With B, knit 6 rows.

Row 7 Rep inc row—71 (76, 81, 86) sts.

Rows 8–14 Knit.

Section 4

With A, work in St st for 20 rows, AT THE SAME TIME, place clip-on st markers at each side on row 7 to match up with the back armhole shaping at the side seam edges.

Section 5

With B, work in Garter st for 26 rows, working the inc row on rows 1 and 15—75 (80, 85, 90) sts. At the end of this Garter section, change to A and cont with A in St st to end of piece.

Shape neck

Next row (RS) With A, k27 (29, 31, 33) sts, sl next 21 (22, 23, 24) sts to a st holder, join a 2nd ball of A and k to end.

Cont to work both sides at once, shape neck binding off 2 sts from each neck edge twice, then bind off 1 st from each neck edge twice, AT THE SAME TIME, when there are 2 (6, 10, 14) rows worked in A, and armhole edge measures $7\frac{1}{4}$ (8, $8\frac{3}{4}$, $9\frac{1}{2}$)in/18.5 (20.5, 22, 24)cm from the placed marker, work as foll:

Shape shoulder

Bind off 2 sts from each shoulder edge 4 times, then bind off 6 (7, 8, 9) sts from each shoulder edge once, 7 (8, 9, 10) sts once.

Back

With size US 4 (3.5mm) needles and A, cast on 141 (147, 153, 159) sts. [Knit 1 row, purl 1 row] twice.

Next row (RS) K1, *p1, k1; rep from * to end.

Next row (WS) P1, *k1, p1; rep from * to end.

Next row (RS) [K2tog, k2] 34 (36, 38, 39) times, then k2tog for 2 (1, 0, 0) times, end k1 (1, 1, 3)—105 (110, 115, 120) sts. Rep between **'s on the front to complete the side slit. The back will be worked in the same stripe patt as the front, only without the side seam inc'ing.

Begin stripe pattern

Change to size US 10 (6mm) needles.

Knit 20 rows with B, work 30 rows in St st with A, knit 14 rows with B, work 6 rows in St st with A.

Shape armhole

Row 1 (RS) With A, k3 sts, join a 2nd ball of yarn and bind off 12 sts, k to the last 15 sts, join another ball of yarn and bind off 12 sts, k rem 2 sts.

Row 2 (WS) P3; p sts of center section; end p3 in last section.

Row 3 (RS) Knit, dec'ing 1 st at end of first section; at the beg and end of 2nd section and at beg of 3rd section.

Row 4 (WS) P2; p sts of center section; end p2 in last section.

Row 5 Rep row 3 fastening off the single st in the first and 3rd sections.

There are 71 (76, 81, 86) sts on needle. Cont to work the same color sections as on front working until there are 20 rows in St st with A, then knit 26 rows with B, rep inc row (same as section 1 on front) on rows 1 and 15 of this section 5—75 (80, 85, 90) sts.

Cont with A only for 2 (6, 10, 14) rows in St st.

Shape shoulder and neck

Bind off 2 sts at beg of next 8 rows—59 (64, 69, 74) sts. On the last WS, pm to mark the center 23 (24, 25, 26) sts.

Next row (RS) Bind off 6 (7, 8, 9) sts, k to center marked sts, sl these center 23 (24, 25, 26) sts to a st holder, join a 2nd ball of yarn and bind off 5 sts, k to end.

Next row (WS) Bind off 6 (7, 8, 9) sts, p to end of first side; on 2nd side, bind off 5 sts, p to end.

Bind off rem 7 (8, 9, 10) sts each side.

Sleeves

With size US 4 (3.5mm) needles and A, cast on 64 (70, 76, 82) sts. [Knit 1 row, purl 1 row] twice.

Next row (RS) *K1, p1; rep from * to end. Rep this rib row once more.

Change to size US 10 (6 mm) needles.

Work in St st for 4 rows.

Inc row (RS) K1, kfb, k to last 3 sts, kfb, k2. Cont in St st, rep inc row every 6th row twice more—70 (76, 82, 88) sts then, change to B and knit 5 rows.

Next row (RS) Rep inc row. Knit 7 rows with B.

Next row (RS) Rep inc row—74 (80, 86, 92) sts.

Change to A and work even in St st for 14 rows.

01 Boxy Pullover



Shape cap

Bind off 6 sts at beg of next 2 rows, 5 sts at beg of next 10 rows. Bind off rem 12 (18, 24, 30) sts.

Finishing

Sew left shoulder seam.

Neckband

With size US 4 (3.5mm) needles and A, pick up and k 6 sts from shaped back neck edge, 23 (24, 25, 26) sts from back holder, pick up and k 6 sts from shaped back neck edge, 19 (22, 25, 28) sts from shaped front neck edge, k 21 (22, 23, 24) sts from front holder, pick up and k 19 (22, 25, 28) sts from shaped front neck edge—94 (102, 110, 118) sts.

[Knit 1 row, purl 1 row] twice. Bind off knitwise.

Sew other shoulder and neckband seam.

Use the clip-on st markers to position the sleeve into the armhole, centering sleeve seam at center of 12-st bind-offs. Sew sleeves into armholes. Sew sleeve seams, sew side seams leaving the hem edge free and reinforce at the top of the slit opening. ■

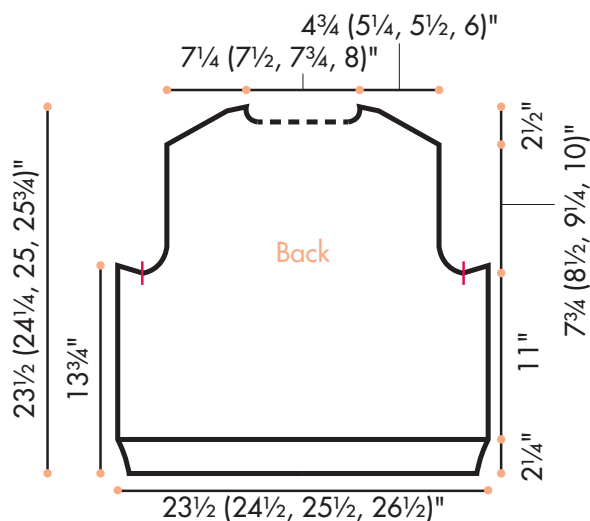
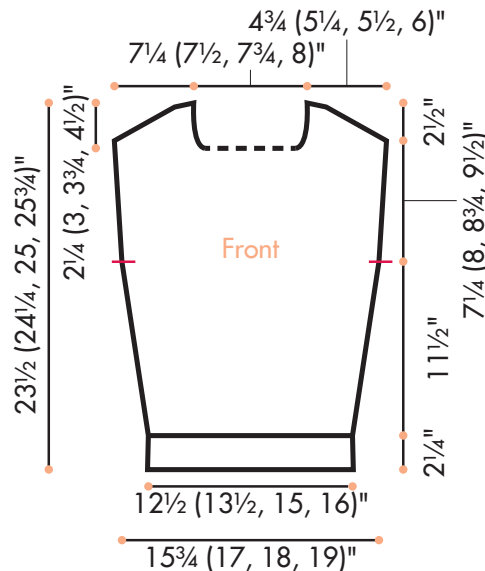

| = Place marker

